

REVISIONS			
REV.	DESCRIPTION	APPROVED	DATE
6	INITIAL RELEASE	GMD	4/12/21

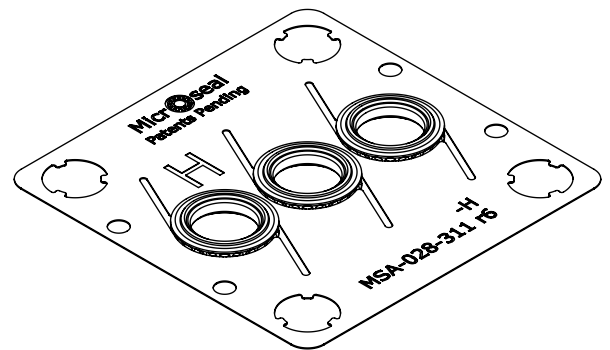
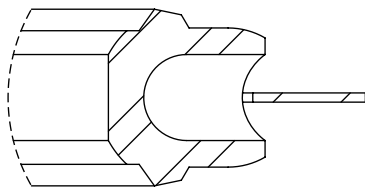
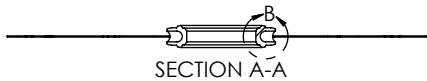
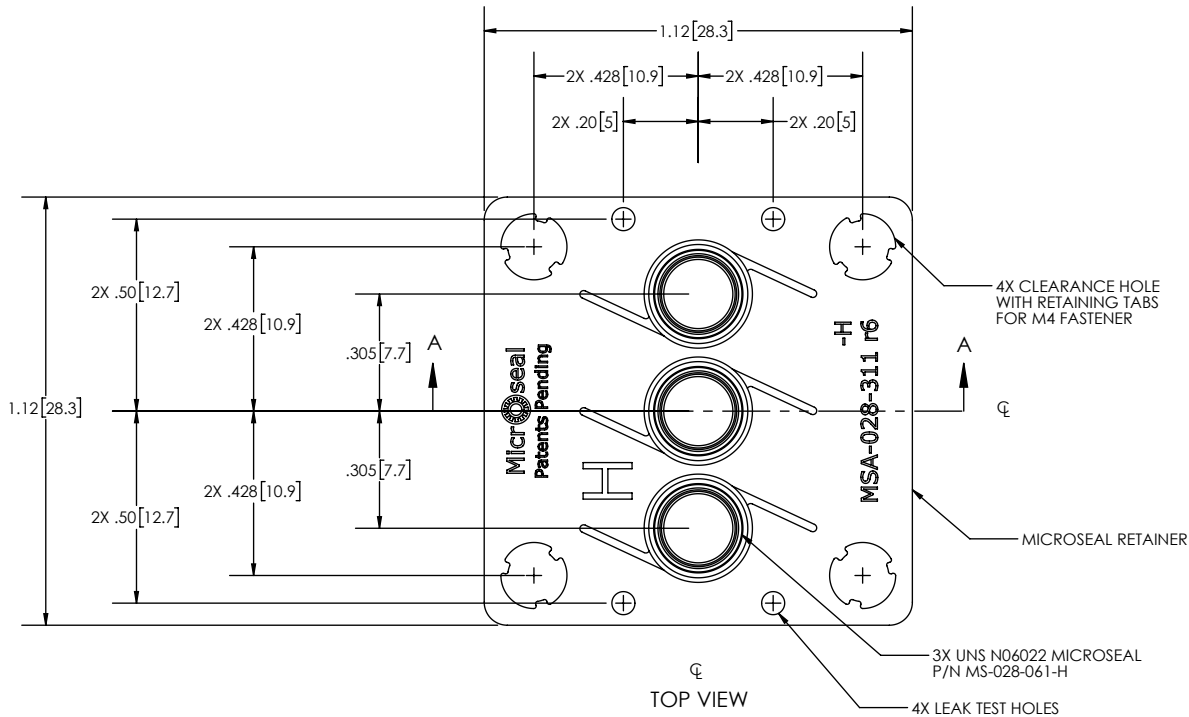

- GENERAL NOTES:
1. PACKAGING: TRIPLE BAG
  2. RETAINER MATERIAL: STAINLESS STEEL 300 SERIES
  3. SEAL MATERIAL: UNS N06022

**MICROFLEX TECHNOLOGIES PROPRIETARY INFORMATION**  
 THIS DRAWING IS THE EXCLUSIVE PROPERTY OF MICROFLEX TECHNOLOGIES LLC, AND EMBODIES A CONFIDENTIAL DESIGN. IT HAS BEEN FORWARDED TO YOU IN STRICT CONFIDENCE FOR A SPECIFIC PURPOSE AND AS A RECIPIENT YOU AGREE NOT TO USE, DISCLOSE, REPRODUCE OR COPY IT IN WHOLE OR IN PART WITHOUT THE EXPRESS WRITTEN CONSENT OF MICROFLEX TECHNOLOGIES LLC, AND TO IMMEDIATELY RETURN THE DRAWING UPON REQUEST.

UNLESS OTHERWISE SPECIFIED:	APPROVALS	DATE
DIMENSIONS ARE IN INCHES DIMENSIONS IN [ ] ARE IN MILLIMETERS	DRWG: JWM	7/30/24
TOLERANCES:	ENG: JWM	7/30/24
FRACTIONAL ± N/A	QA: GMD	7/30/24
ANGULAR: MACH ± .5°	THIRD ANGLE PROJECTION	
TWO PLACE DECIMAL ± .01		
THREE PLACE DECIMAL ± .003		
MATERIAL SEE GENERAL NOTES		
FINISH N/A		

<p><b>Microflex Technologies</b> 430 W COLLINS AVE, ORANGE, CA 92867</p>			
<b>TITLE:</b> MICROSEAL ASSEMBLY, UNS N06022 SEAL, SERIES 60 SURFACE MOUNT, SEMI PR3.1 COMPONENT 3 PORT, 1.125" W			
SIZE C	SCALE 2:1	DRAWING NO. MSA-028-311-H	REV 6
DO NOT SCALE DRAWING			SHEET 1 OF 1